

PROGRAMMING FOR PROBLEM SOLVING -- PPS SUBJECT CODE-- BTPS-101-18



*By
Dr.A.Deepa,AP,Chandigarh
Engineering College*

BOOTING OF A COMPUTER SYSTEM

WHY IS BOOTING REQUIRED ?

- ✘ Hardware doesn't know where the operating system resides and how to load it.
- ✘ Need a special program to do this job – **Bootstrap loader**.
 - + E.g. BIOS – Boot Input Output System.
- ✘ Bootstrap loader locates the kernel, loads it into main memory and starts its execution.
- ✘ In some systems, a simple bootstrap loader fetches a more complex boot program from disk, which in turn loads the kernel.

HOW BOOT PROCESS OCCURS ?

- ✘ Reset event on CPU (power up, reboot) causes instruction register to be loaded with a predefined memory location. It contains a jump instruction that transfers execution to the location of Bootstrap program.
- ✘ This program is form of ROM, since RAM is in unknown state at system startup. ROM is convenient as it needs no initialization and can't be affected by virus.

BIOS INTERACTION

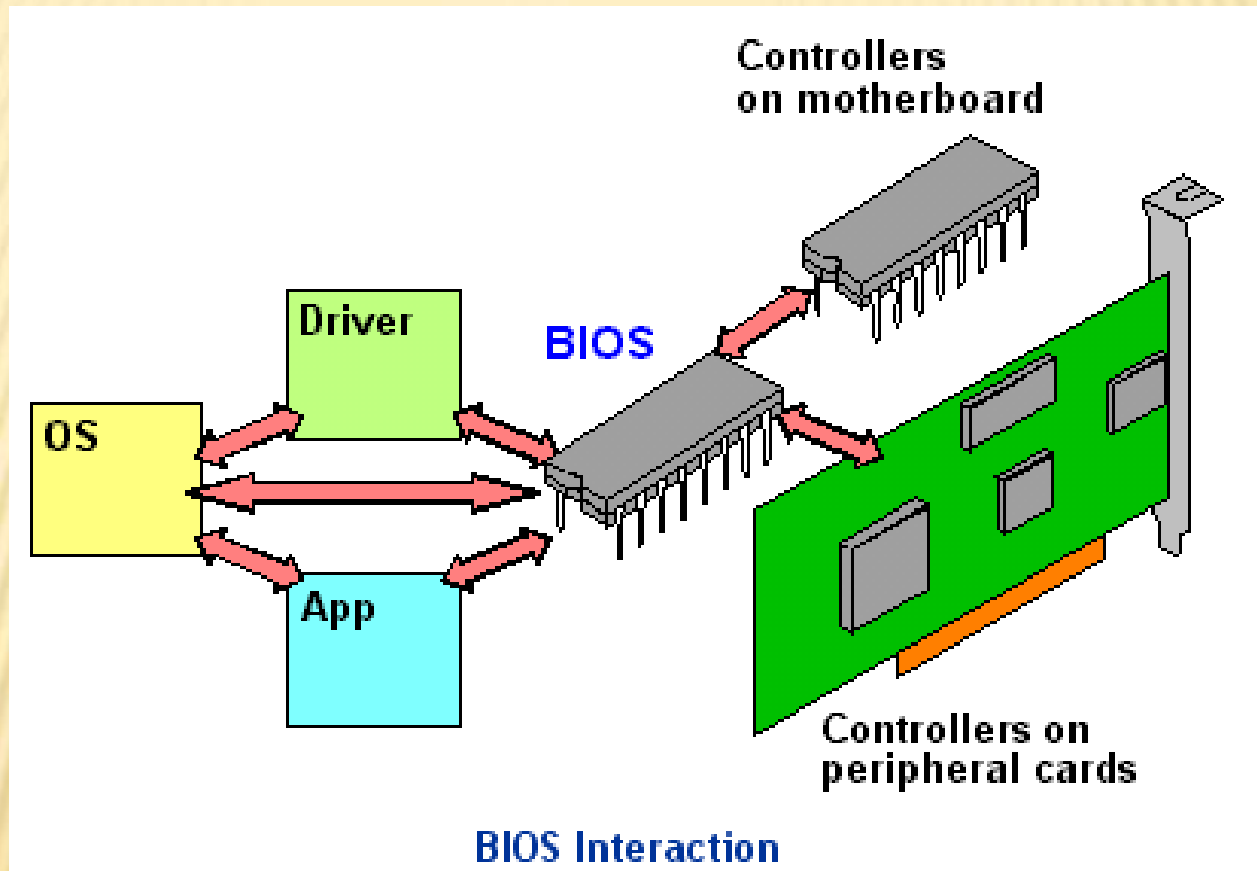

TASKS PERFORMED AT BOOT UP

- ✘ Run diagnostics to determine the state of machine. If diagnostics pass, booting continues.
- ✘ Runs a Power-On Self Test (*POST*) to check the devices that the computer will rely on, are functioning.
- ✘ BIOS goes through a preconfigured list of devices until it finds one that is bootable. If it finds no such device, an error is given and the boot process stops.
- ✘ Initializes CPU registers, device controllers and contents of the main memory. After this, it loads the OS.

BIOS SETUP

PhoenixBIOS Setup Utility						
Main	Advanced	Security	Power	Boot	Exit	
ATAPI CD-ROM Drive +Removable Devices +Hard Drive Network Boot					Item Specific Help	
					Keys used to view or configure devices: <Enter> expands or collapses devices with a + or - <Ctrl+Enter> expands all <Shift + 1> enables or disables a device. <+> and <-> moves the device up or down. <n> May move removable device between Hard Disk or Removable Disk <d> Remove a device that is not installed.	
F1	Help	↑↓	Select Item	-/+	Change Values	F9 Setup Defaults
Esc	Exit	←	Select Menu	Enter	Select ▶ Sub-Menu	F10 Save and Exit

BOOT PROCEDURE

```

PU Clock      : 2000MHz          L1 Cache Size : 128K
                                           L2 Cache Size : 256K

iskette Drive A : 1.44M, 3.5"    Display Type   : EGA/AGA
iskette Drive B : None          Serial Port(s) : 3F8 2F8
ri. Master Disk : None          Parallel Port(s) : 378
ri. Slave Disk  : None          DDR SDRAM at Bank : 0 1
ec. Master Disk : None
ec. Slave Disk  : None

Devices Listing ...
  Dev Fun Vendor Device SUID SSID Class Device Class      IRQ
-----
  16  0  1106  3038  1458  5004  0C03  USB 1.1 Host Cntrlr  10
  16  1  1106  3038  1458  5004  0C03  USB 1.1 Host Cntrlr  10
  16  2  1106  3038  1458  5004  0C03  USB 1.1 Host Cntrlr  11
  16  3  1106  3104  1458  5004  0C03  USB 2.0 Host Cntrlr  11
  17  1  1106  0571  1458  5002  0101  IDE Cntrlr           14
  17  5  1106  3059  1458  A002  0401  Multimedia Device    11
  19  0  10EC  8139  10EC  8139  8200  Network Cntrlr       11
   0  0  100E  0020  0000  0000  0300  Display Cntrlr       10
                                           ACPI Controller      9

ifgng DMI Pool Data ..... Update Success
K BOOT FAILURE, INSERT SYSTEM DISK AND PRESS ENTER

```

TASKS PERFORMED AT BOOT UP (CONTD)

- ✘ On finding a bootable device, the BIOS loads and executes its boot sector. In the case of a hard drive, this is referred to as the master boot record (*MBR*) and is often not OS specific.
- ✘ The MBR code checks the partition table for an active partition. If one is found, the MBR code loads that partition's boot sector and executes it.
- ✘ The boot sector is often operating system specific, however in most operating systems its main function is to load and execute a kernel, which continues startup.

SECONDARY BOOT LOADERS

- ✘ If there is no active partition or the active partition's boot sector is invalid, the MBR may load a secondary boot loader and pass control to it and this secondary boot loader will select a partition (often via user input) and load its boot sector.
- ✘ Examples of secondary boot loaders
 - + GRUB – GRand Unified Bootloader
 - + LILO – LInux LOader
 - + NTLDR – NT Loader

GRUB LOADER

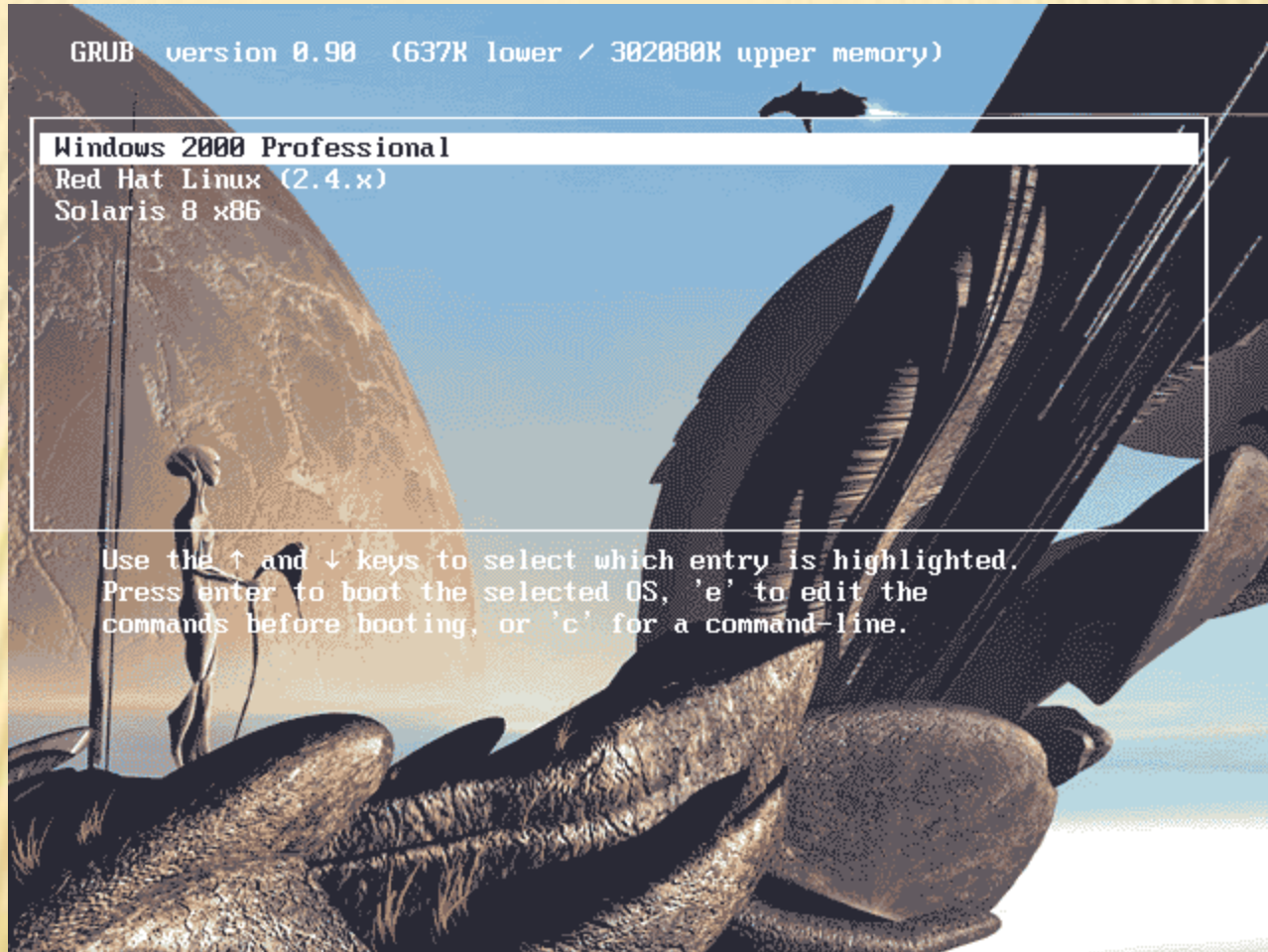

BOOTING AND ROM

- ✘ System such as cellular phones, PDAs and game consoles stores entire OS on ROM. Done only for small OS, simple supporting hardware, and rugged operation.
- ✘ Changing bootstrap code would require changing ROM chips.
 - + EPROM – Erasable Programmable ROM.
- ✘ Code execution in ROM is slower. Copied to RAM for faster execution.

EXAMPLE : DOS

- ✘ After identifying the location of boot files, BIOS looks at the first sector (512 bytes) and copies information to specific location in RAM (7C00H) - **Boot Record**.
- ✘ Control passes from BIOS to a program residing in the boot record.
- ✘ Boot record loads the initial system file into RAM. For DOS, it is IO.SYS .
- ✘ The initial file, IO.SYS includes a file called SYSINIT which loads the remaining OS into the RAM.
- ✘ SYSINIT loads a system file MSDOS.SYS that knows how to work with BIOS.
- ✘ One of the first OS files that is loaded is the system configuration file, CONFIG.SYS in case of DOS. Information in the configuration file tells loading program which OS files need to be loaded (e.g. drivers)
- ✘ Another special file that is loaded is one which tells what specific applications or commands user wants to be performed as part of booting process. In DOS, it is AUTOEXEC.BAT. In Windows, it's WIN.INI .

QUESTIONS

- ✘ What is the effect on boot sector and boot loader when you install two OS, for e.g. Windows and Linux in two separate partitions ?
- ✘ Suppose, you install Windows first. The default boot loader installed in MBR is NTLDR and contains information regarding the active partition of Windows. When you install Linux on this system, the installation prompts to overwrite a new secondary boot loader which identifies both Windows and Linux active partitions and therefore we get a choice of booting the desired OS when the system is started.

In contrast, if Linux is installed first and then Windows, the Windows Installer overwrites the MBR with its own boot loader which doesn't recognize the Linux active partition. This creates a problem. The problem can be corrected by using a LiveCD or any bootable disc which can be used to reinstall a secondary boot loader which identifies both the OS and gives true choice.

QUESTIONS

(1) Why is ROM slower than RAM ?

Semi-conductor Technology used in constructing these two type of memories. RAM is based on positive feedback/capacitive charge for storing the information while ROM contains permanent and non-changeable information stored in its structure.